

LN32240T024SA3098

2.4 inch, 240*320 pixels resolution, RGB interface, TN-TFT-LCD



Disclaimer: The product design is subject to alternation and improvement without prior notice.

Table of Contents

1 General Feature.....	3
2 Mechanical Drawing.....	4
3 Input/Output Terminals.....	5
4 Electrical Characteristics.....	6
5 Timing Characteristics.....	7
6 Optical Characteristics.....	10
7 Environmental Reliability Test.....	14
8 Packing Capacity & Dimension.....	15
9 Appearance Inspection.....	16
10 Precautions for Use of LCD Modules.....	19
11 LCD Introduction.....	20

1 General Feature

Feature		Description	Unit
Display Spec.	Size	2.4	inch
	Resolution	240(H)*320(V)	pixels
	Pixel Configuration	RGB stripe	-
	Pixel Pitch	0.153(H)*RGB*0.153(V)	mm
	Viewing Direction	6 o'clock	-
Mechanical Characteristics	Outside Dimension	42.72(W)*59.40(H)*2.30(D)	mm
	Active Area	36.72(W)*48.96(H)	mm
	Luminance	300	cd/m ²
	LED Numbers	4 LEDs	-
	Pin Order	From left to right 40PIN_0.5mm	-
	Weight	9	g
Electrical Characteristics	Interface	RGB_18bit	-
	Color Depth	262K	colors
	Driver Condition	2.8(Type)	V
	Driver IC	ILI9341	-
Temperature Range	Operating Temp.	-20~70	°C
	Storage Temp.	-30~80	°C

Note: Requirements on Environmental Protection: RoHS.

2 Mechanical Drawing

It is recommended that the window opening of the cabinet be about 0.4MM larger than the AA single side of LCD to avoid light leakage.

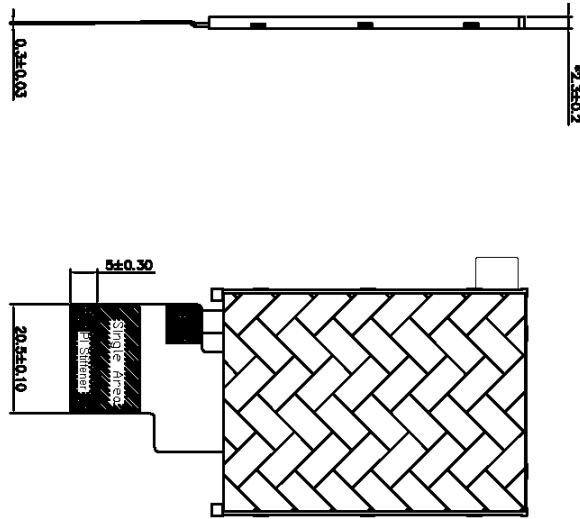
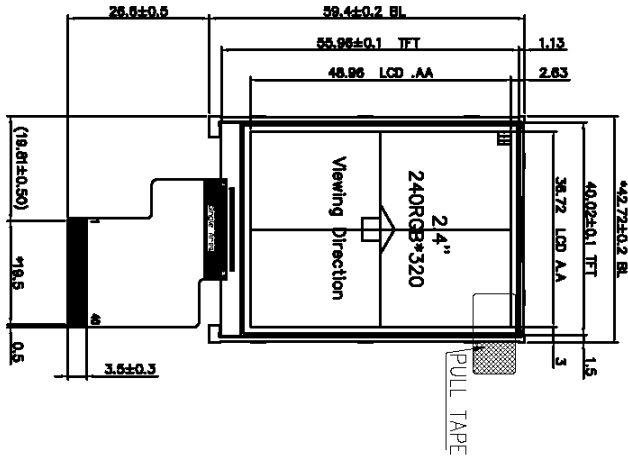

LED A ~~LEDK~~ LEDK
LED CIRCUIT DIAGRAM.

- NOTES:
1. DISPLAY TYPE : 262K COLOR TFT-LCD, TRANSMISSIVE, NORMALLY WHITE;
 2. OPERATING TEMP: -20°C~70°C;
 3. STORAGE TEMP: -30~80°C
 4. LCD DRIVER: ILI9341;
 5. Backlight: 4 Chip-White LEDs, Module BRIGHTNESS: 300cd/m²(typ);
 6. GENERAL TOLERANCE: ±0.2mm;
 7. Mark "*" as the key size , in line with "ROHS" standard.

DWIN Technologies				MODULE NO: LN32240T024SA3098		
				SCALE	NTS	UNIT
TITLE	LCM OUTLINE DIMENSION		PREPARED	DATE		
D/N		PAGE	CHECK	DATE		
VER	A	REV	0	APPROVED		

No	PIN NAME	No	PIN NAME
1	LEDK	21	GND
2	LEDA	22	GND
3	GND	23	B0
4	VCC	24	B1
5	GND	25	B2
6	GND	26	B3
7	R0	27	B4
8	R1	28	B5
9	R2	29	GND
10	R3	30	CLK
11	R4	31	NC
12	R5	32	HSYNC
13	GND	33	VSYNC
14	GND	34	DEN
15	G0	35	NC
16	G1	36	GND
17	G2	37	OS
18	G3	38	SCL
19	G5	39	SDA
20	G6	40	RESET

3 Input/Output Terminals

Pin NO.	Symbol	Function	Remark
1	LEDK	Back light cathode	
2	LEDA	Back light anode	
3	GND	Ground	
4	VCC	Power supply	
5-6	GND	Ground	
7-12	R0-R5	Data bus	
13-14	GND	Ground	
15-20	G0-G5	Data bus	
21-22	GND	Ground	
23-28	B0-B5	Data bus	
29	GND	Ground	
30	PCLK	Clock signal	
31	NC	Not connect	
32	HSYNC	Line synchronizing signal	
33	VSYNC	Frame synchronizing signal	
34	DEN	Data ENABLE signal	
35	NC	Not connect	
36	GND	Ground	
37	CS	A Chip Select signal	
38	SCL	Serial clock input for SPI interface	
39	SDA	Serial data input/output bidirectional pin for SPI interface	
40	RESET	Reset Signal pin	

4 Electrical Characteristics

4.1 Driving TFT LCD Panel

Item	Symbol	Min.	Typ.	Max.	Unit	Remark
Analog Voltage	VCC	2.6	2.8	3.3	V	
Input Logic High Voltage	VIH	0.7VCC	-	VCC	V	
Input Logic Low Voltage	VIL	GND	-	0.3VCC	V	
Output Logic High Voltage	VOH	0.8VCC	-	VCC	V	
Output Logic Low Voltage	VOL	GND	-	0.2VCC	V	

4.2 LED Backlight Specification

Item	Symbol	Min.	Typ.	Max.	Unit	Remark
Forward Voltage	VF	11.2	12.8	13.2	V	
Forward Current	IF	-	20	-	mA	
Luminance	Lv	-	300	-	cd/m ²	If=20mA
Power Consumption	PLED	-	256	-	mW	
Uniformity(with L/G)	Avg	75	80	-	%	
LED Life Time	Hr	-	30000	-	Hour	

Note: The LED Supply Voltage is defined by the number of LED at Ta=25°C, and IL=20mA/LED.

Note: The "LED life time" is defined as the module luminance decrease to 50% original brightness at Ta=25°C and IL=20mA/LED. The LED lifetime could be decreased if operating IL is large than 20mA/LED.



5 Timing Characteristics

5.1 3-line Serial Interface Characteristics

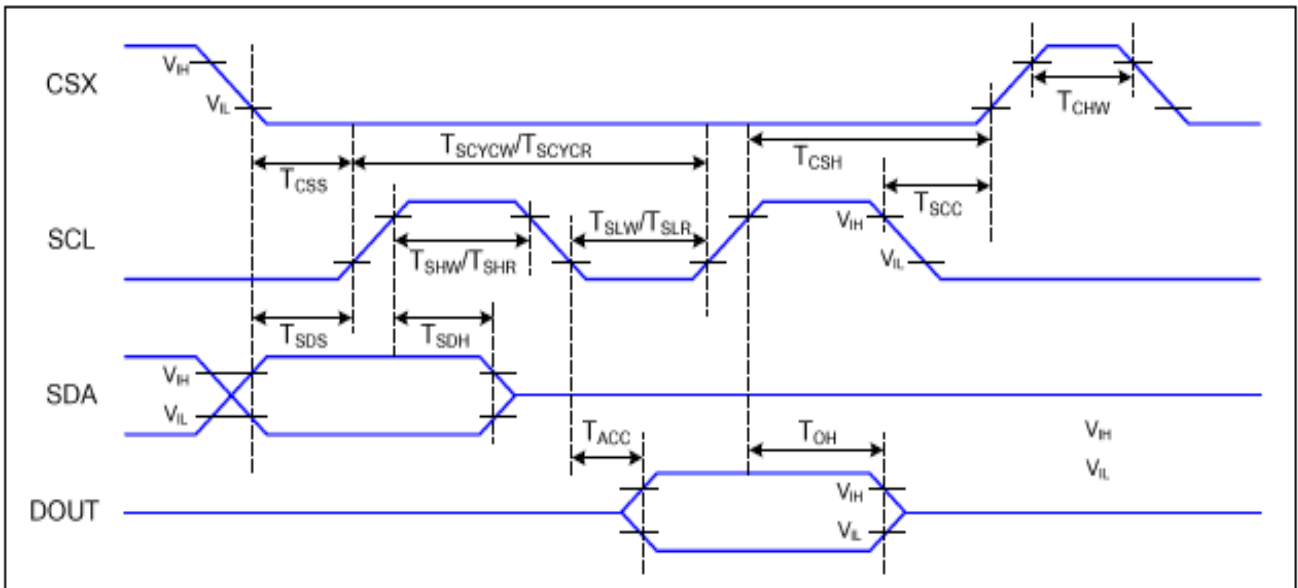

Signal	Symbol	Parameter	min	max	Unit
SCL	tscydw	Serial Clock Cycle (Write)	100	-	ns
	tshw	SCL "H" Pulse Width (Write)	40	-	ns
	tslw	SCL "L" Pulse Width (Write)	40	-	ns
	tscydr	Serial Clock Cycle (Read)	150	-	ns
	tshr	SCL "H" Pulse Width (Read)	60	-	ns
	tslr	SCL "L" Pulse Width (Read)	60	-	ns
SDA / SDI (Input)	tsds	Data setup time (Write)	30	-	ns
	tsdh	Data hold time (Write)	30	-	ns
SDA / SDO (Output)	tacc	Access time (Read)	10	-	ns
	toh	Output disable time (Read)	10	50	ns
CSX	tsccl	SCL-CSX	20	-	ns
	tchwh	CSX "H" Pulse Width	40	-	ns
	tcss	CSX-SCL Time	60	-	ns
	tcswh		65	-	ns

5.2 RGB Interface Characteristics

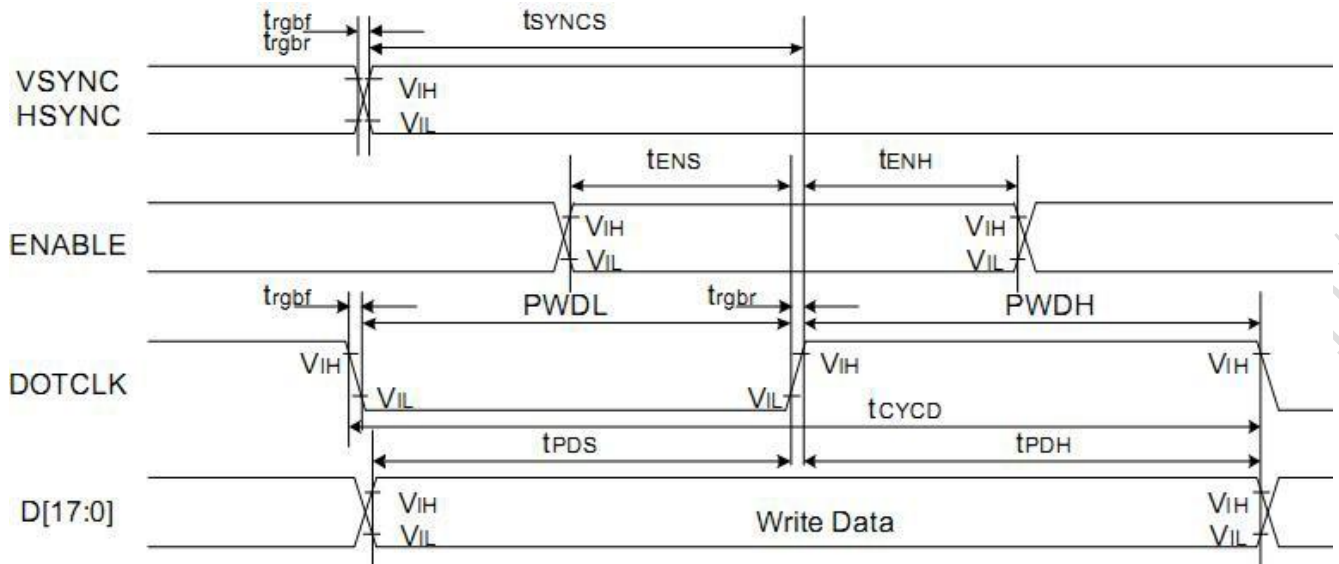

Signal	Symbol	Parameter	min	max	Unit
VSYNC / HSYNC	t_{SYNCS}	VSYNC/HSYNC setup time	15	-	ns
	t_{SYNCH}	VSYNC/HSYNC hold time	15	-	ns
DE	t_{ENS}	DE setup time	15	-	ns
	t_{ENH}	DE hold time	15	-	ns
D[17:0]	t_{POS}	Data setup time	15	-	ns
	t_{PDH}	Data hold time	15	-	ns
DOTCLK	PWDH	DOTCLK high-level period	15	-	ns
	PWDL	DOTCLK low-level period	15	-	ns
	t_{CYCD}	DOTCLK cycle time	100	-	ns
	t_{rgb}, t_{rgb}	DOTCLK, HSYNC, VSYNC rise/fall time	-	15	ns

5.3 RGB Interface Definition

Parameters	Symbols	Condition	Min.	Typ.	Max.	Units
Horizontal Synchronization	Hsync		2	10	16	DOTCLK
Horizontal Back Porch	HBP		2	20	24	DOTCLK
Horizontal Address	HAdr		-	240	-	DOTCLK
Horizontal Front Porch	HFP		2	10	16	DOTCLK
Vertical Synchronization	Vsync		1	2	4	Line
Vertical Back Porch	VBP		1	2	-	Line
Vertical Address	VAdr		-	320	-	Line
Vertical Front Porch	VFP		3	4	-	Line

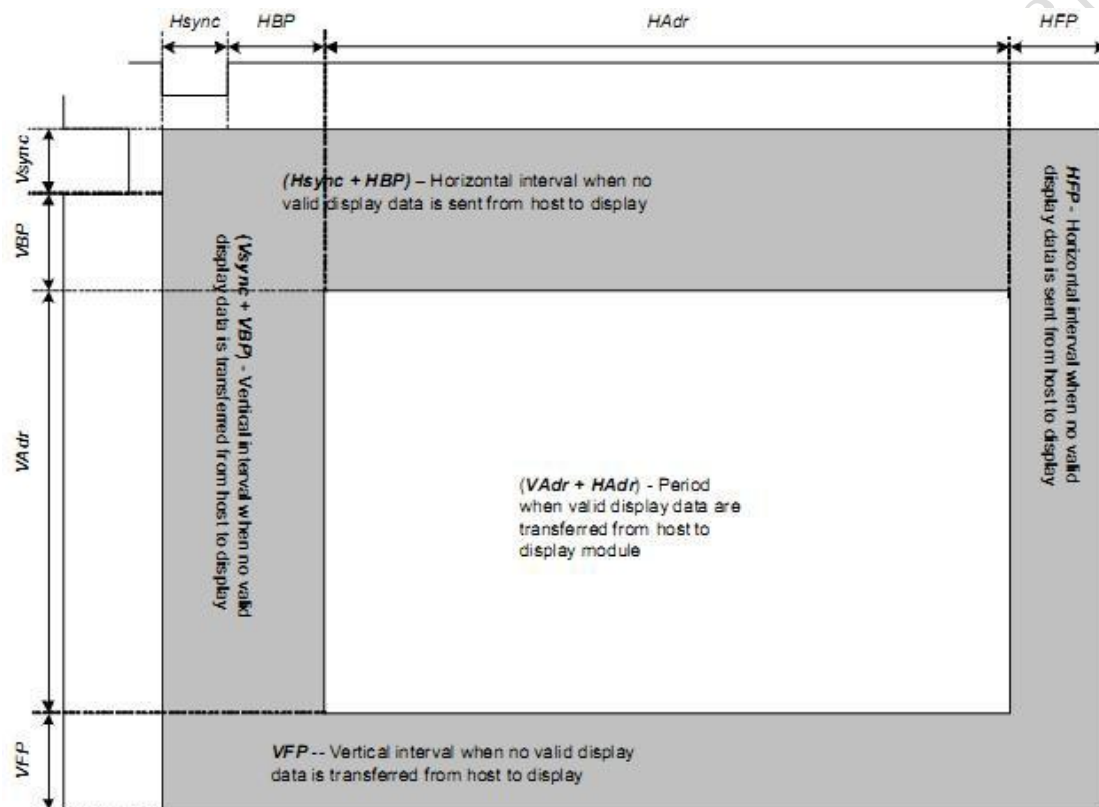

5.4 Reset Timing

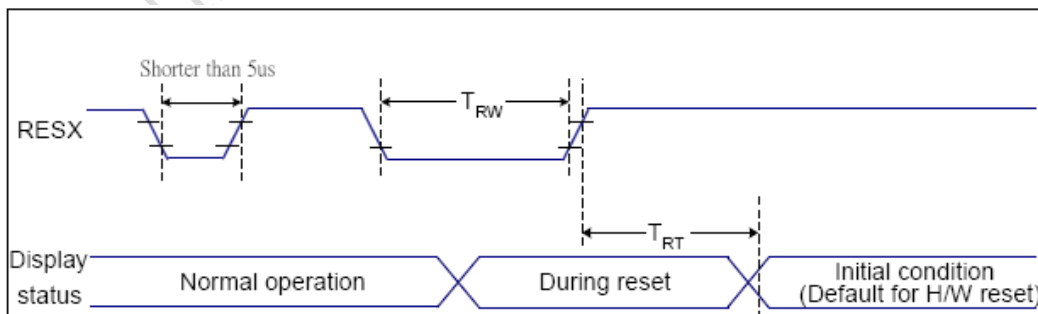

Related Pins	Symbol	Parameter	MIN	MAX	Unit
RESX	TRW	Reset pulse duration	10	-	us
	TRT	Reset cancel	-	5	ms
				120	ms

5.5 Power Sequence

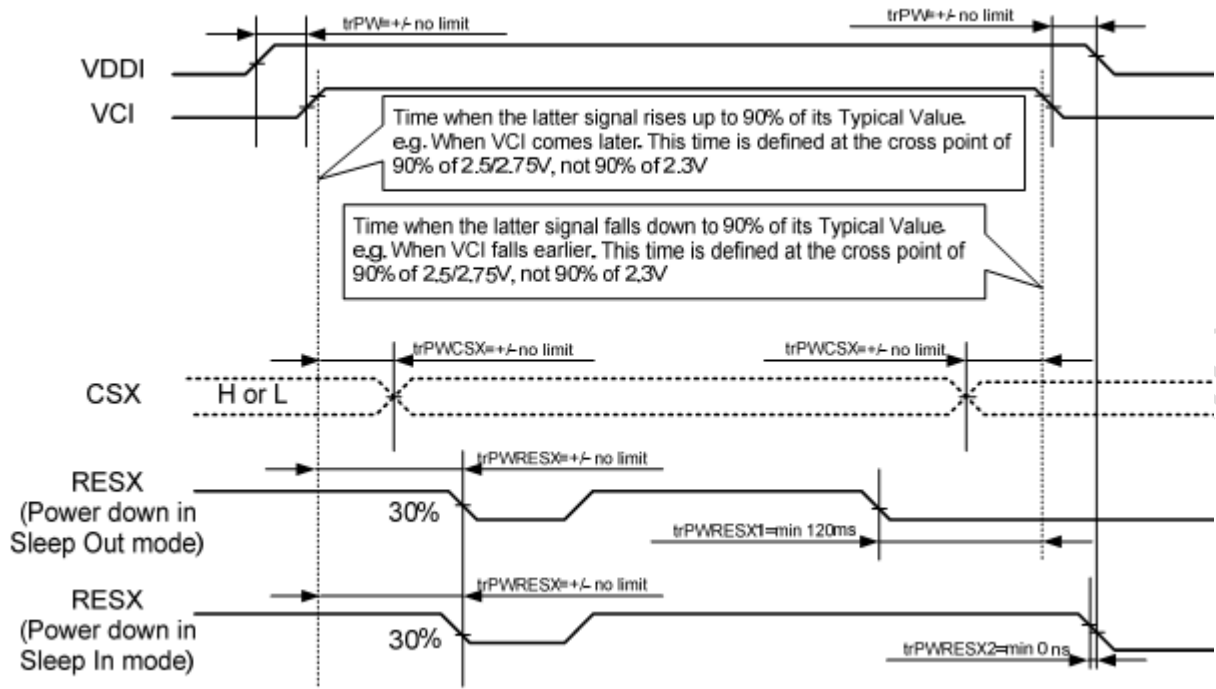

Case 1 - RESX line is held High or Unstable by Host at Power ON

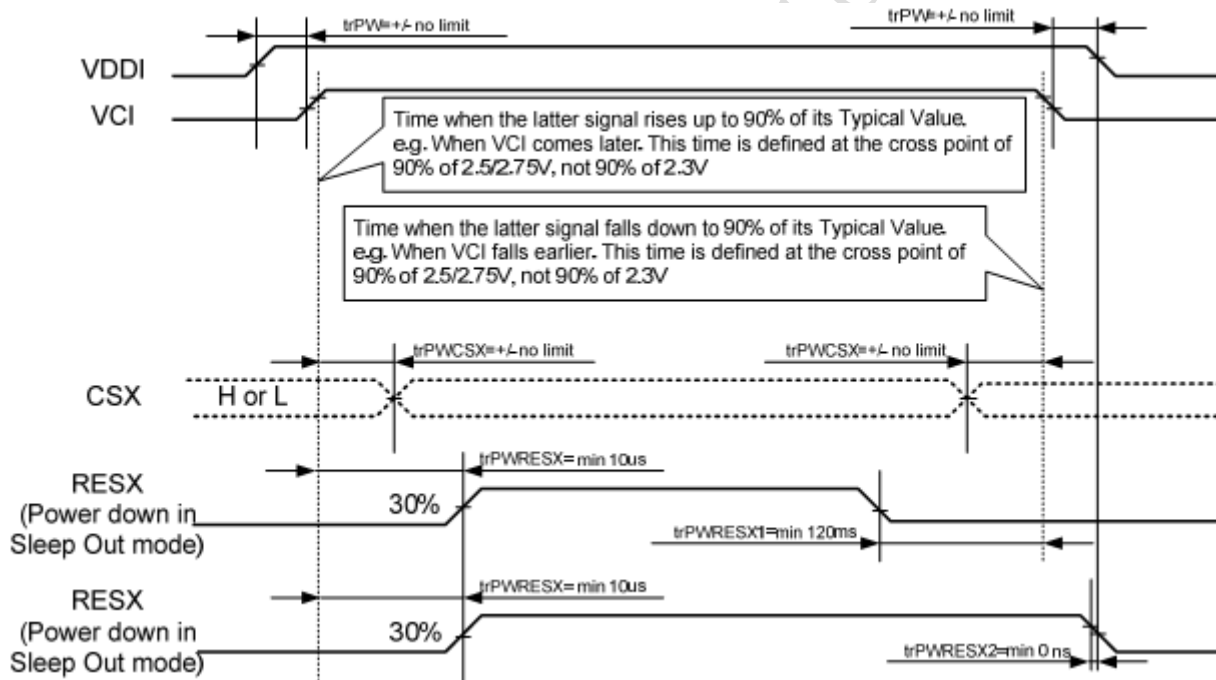

Case 2 - RESX line is held Low by Host at Power ON

6 Optical Characteristics

Item	Symbol	Condition	Min.	Typ.	Max.	Unit	Remark
Viewing Angle	Top	$CR \geq 10$	-	45	-	Deg.	Note 2,3
	Bottom		-	20	-		
	Left		-	45	-		
	Right		-	45	-		
Contrast Ratio	CR	$\theta=0^\circ$	-	250	-		Note 3
Response Time	T_r+T_f	$\theta=0^\circ$	-	30		ms	
Color Chromaticity (CIE1931)	Wx	$\theta=0^\circ$	0.288	0.308	0.328		Note 1,5
	Wy		0.305	0.325	0.345		
	Rx		0.592	0.612	0.632		
	Ry		0.309	0.329	0.349		
	Gx		0.279	0.299	0.319		
	Gy		0.547	0.567	0.587		
	Bx		0.124	0.144	0.164		
	By		0.090	0.110	0.130		
Transmittance	Trans	$\theta=0^\circ$	4.5	5.0	-	%	

Test conditions:

IF= 20 mA, and the ambient temperature is 25°C.

Note 1: Definition of optical measurement system.

The optical characteristics should be measured in dark room. After 5 minutes operation, the optical properties are measured at the center point of LCD.

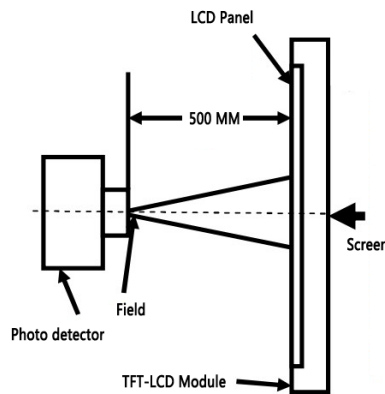

Note 2: Definition of viewing angle range and measurement system.

The viewing angle is measured at the center point of the LCD by BM-7A.

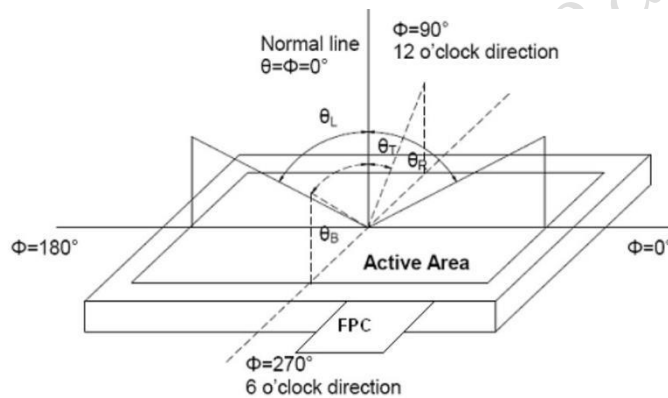

Note 3: Definition of contrast ratio.

$$\text{Contrast ratio (CR)} = \frac{\text{Luminance measured when LCD is on the "White" state}}{\text{Luminance measured when LCD is on the "Black" state}}$$

“White state “: The state is that the LCD should drive by V_{white} .

“Black state”: The state is that the LCD should drive by V_{black} .

V_{white} : To be determined V_{black} : To be determined.

Note 4: Definition of response time.

The response time is defined as the LCD optical switching time interval between “White” state and “Black” state. Time ON (TON) is the time between photo detector output intensity changed from 90% to 10%. And time off (TOFF) is the time between photo detector output intensity changed from 10% to 90%.

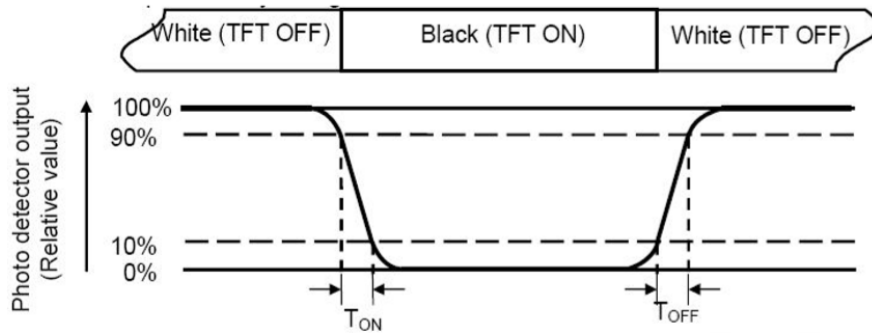

Note 5: Definition of color chromaticity (CIE1931).

Color coordinates measured at center point of LCD.

Note 6: Definition of luminance uniformity

Active area is divided into 9 measuring areas (Refer Fig. 2). Every measuring point is placed at the center of each measuring area.

Luminance Uniformity (U) = L_{min} / L_{max}

L-----Active area length W----- Active area width

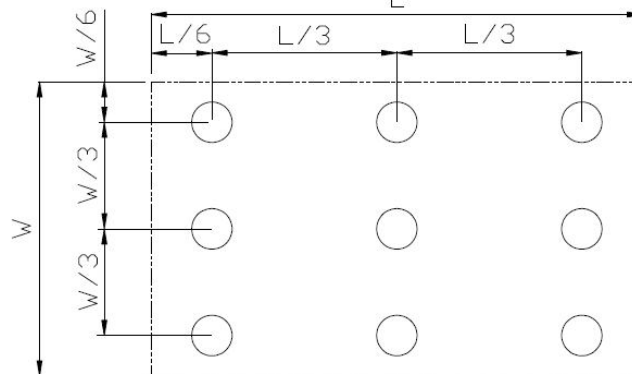

L_{max} : The measured Maximum luminance of all measurement position.

L_{min} : The measured Minimum luminance of all measurement position.

Note 7: Definition of luminance.

Measure the luminance of white state at center point.

7 Environmental Reliability Test

NO	Test Item	Condition	Remarks
1	High Temperature Operation	Ta=+70°C,48hours	IEC60068-2-1:2007 GB2423.2-2008
2	Low Temperature Operation	Ta=-20°C,48hours	IEC60068-2-1:2007 GB2423.1-2008
3	High Temperature Storage	Ta=+80°C,48hours	IEC60068-2-1:2007 GB2423.2-2008
4	Low Temperature Storage	Ta=-30°C,48hours	IEC60068-2-1:2007 GB2423.1-2008
5	Storage at High Temperature and Humidity	Ta=+40°C,90% RH max,48hours	IEC60068-2-78 :2001 GB/T2423.3-2006
6	Thermal Shock (non-operation)	-20°C /30min +70°C/30min, Change time:5min,10cycles	Start with cold temperature, End with high temperature, IEC60068-2-14:1984, GB 2423.22-2002

8 Packing Capacity & Dimension

Dimension			
Dimension(mm)	42.72(W)*59.40(H)*2.30(D)		
Net Weight	9g		
Packing Capacity			
Size	LCD Size and Resolution	Layer	Quantity(Pcs)
220mm(L)x160mm(W)x47mm(H)	2.4 inch 240*320	1	1
600mm(L)x450mm(W)x300mm(H)	2.4 inch 240*320	2	240

Packing instruction:

The LCD is placed in the grid, covered with a PE static bag and compactly assembled, the upper and the lower layers of the grid are protected by buffer spaces.

The LCD covered with a PE static bag and compactly assembled



placed in the grid



The upper and the lower layers of the grid are protected by buffer spaces



Packed



9 Appearance Inspection

9.1 General rules for inspection

9.1.1 Anti-static wearables (anti-static wristbands, gloves) must be worn during the inspection.

9.1.2 Do not use bare hands to touch the position of the device, golden fingers, and the surface of the screen to prevent the sweat from human hands from causing oxidation and affecting the appearance.

9.1.3 It is forbidden to stack products out of specification and handle them with care to avoid damage to components.

9.1.4 The repaired products need to be inspected to prevent rosin and tin slag from exceeding the specifications.

9.1.5 When technical documents and process documents have specific requirements for products, the technical documents and process documents shall be the main requirements.

9.2 Inspection conditions

9.2.1 The conditions of display function check

Angle: $\pm 5^\circ$;

Inspection method: visual inspection. The inspection object is 30-40cm away from the light source, and the eye is 30-40cm away from the inspection object;

Illumination: 300-500Lux;

Inspection time: 5-10S.

9.2.2 Visual inspection conditions

Angle: $\pm 45^\circ$;

Inspection method: visual inspection. The inspection object is 30-40cm away from the light source, and the eye is 30-40cm away from the inspection object;

Illumination: 800-1500Lux;

Inspection time: 5-10S.

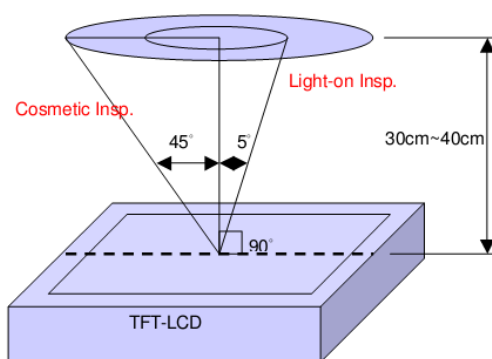

9.3 Inspection standards

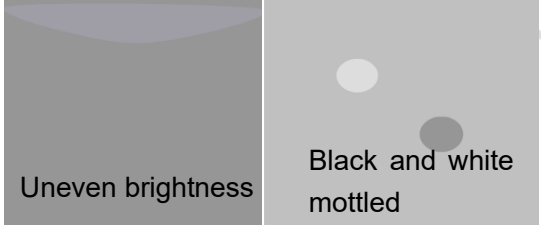
Type	Test Items	Judgement Standard	Defect Category
Display state	Dead pixels	No dead pixels	
	mura	<p>From different angles, the brightness is required to be uniform. Under the 64-level grayscale or pure black interface, there should be no uneven display brightness within the viewing angle range of 45° through 6% ND FILTER. Y series (TV film) LCD screen does not have specific requirements, and the picture inspection does not affect the display as qualified.</p> 	Slight defect
	Light leakage	<p>Under the 64-level grayscale or pure black interface, there should be no obvious light leakage within the viewing angle range of 45° by visual inspection or through 6% ND FILTER. Y series (TV LCD screen) series can be without obvious visual defects.</p>	Slight defect
	Linear foreign bodies	<p>1. $W \leq 0.05$, $L \leq 2\text{mm}$, negligible; 2. $0.05\text{mm} < W \leq 0.1\text{mm}$, $L \leq 2\text{mm}$, $N \leq 3$; 3. $W > 0.1\text{mm}$, $L > 2\text{mm}$, not allowed.</p>	Slight defect
Screen surface	Within the effective area	<p>Spotted: 1. $D \leq 0.2\text{mm}$ and it is not a piece, it is not counted; 2. $0.2\text{mm} < D \leq 0.5\text{mm}$, $N \leq 3$; 3. $D > 0.5\text{mm}$, $L > 0.5\text{mm}$, $W > 0.5\text{mm}$ are not allowed; (The spotted foreign objects shall not exceed the point-line gauge $D=0.5$, and the black dot coverage shall be checked, and the spotted foreign objects shall be judged within the range of $D=0.5$)</p>	Slight defect

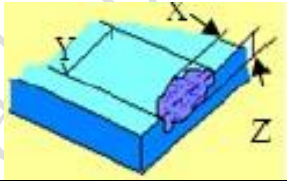
	Foreign objects Scratch Air bubbles	Linear: 1. $W \leq 0.05$, $L \leq 2\text{mm}$, ignored; 2. $0.05 < W \leq 0.1\text{mm}$, $L \leq 2\text{mm}$, $N \leq 3$; 3. $W > 0.1\text{mm}$, $L > 2\text{mm}$, not allowed.	
	Outside the effective area Foreign objects Scratches Air bubbles	Foreign objects are not checked, and bubbles are not allowed to $D > 1\text{mm}$; Non-inductive scratches of no more than $0.1 \times 8\text{mm}$ are allowed.	Slight defect
	Crack	Not allowed.	 Slight defect
	Notch	1. Does not affect the appearance from the front; 2. Does not affect the relevant alignment; 3. $X \leq 1\text{mm}$, $Y \leq 1\text{mm}$, $N \leq 2$.	 Slight defect
	Glass side Foreign objects Dirty	1. The foreign body on the side is not controlled; 2. The paint pen marks on the side are not controlled; 3. Side oily note printing is not allowed.	Slight defect
FPC	Cracks Goldfinger crease	Not allowed.	Heavy deficit
	Crease	Slight creases are not controlled; The crease is whitish and has lines, which is not allowed.	Heavy deficit
	Top wound, stab wound	No damage to the line, $D \leq 0.2\text{mm}$; Damage to the line is not allowed.	Heavy deficit
	Scratch	Slight scratches on the surface are not controlled; Damage to the line is not allowed.	Heavy deficit
	Goldfinger scratch	$W \leq 0.05\text{mm}$, no control; $W > 0.05\text{mm}$, not allowed; Test probe tip marks are not controlled.	Heavy deficit
	Component	Under-soldering, over-soldering and false soldering are not allowed.	Heavy deficit

10 Precautions for Use of LCD Modules

10.1 Handling Precautions

10.1.1 The display panel is made of glass. Do not subject it to a mechanical shock by dropping it from a high place, etc.

10.1.2 If the display panel is damaged and the liquid crystal substance inside it leaks out, be sure not to get any in your mouth, if the substance comes into contact with your skin or clothes, promptly wash it off using soap and water.

10.1.3 Do not apply excessive force to the display surface or the adjoining areas since this may cause the color tone to vary.

10.1.4 The polarizer covering the display surface of the LCD module is soft and easily scratched. Handle this polarizer carefully.

10.1.5 If the display surface is contaminated, breathe on the surface and gently wipe it with a soft dry cloth. If still not completely clear, Can only use LCD dedicated cleaner, the following organic solvent can not be used:

- Isopropyl alcohol
- Ethyl alcohol
- Ketone
- Aromatic solvents

10.1.6 Do not attempt to disassemble the LCD Module.

10.1.7 If the logic circuit power is off, do not apply the input signals.

10.1.8 To prevent destruction of the elements by static electricity, be careful to maintain an

10.1.9 optimum work environment.

10.1.9.1 Be sure to ground the body when handling the LCD Modules.

10.1.9.2 Tools required for assembly, such as soldering irons, must be properly ground.

10.1.9.3 To reduce the amount of static electricity generated, do not conduct assembly and other work under dry conditions.

10.1.9.4 The LCD Module is coated with a film to protect the display surface. Be care when peeling off this protective film since static electricity may be generated.

10.2 Storage precautions

10.2.1 When storing the LCD modules, avoid exposure to direct sunlight or to the light of fluorescent lamps.

10.2.2 The LCD modules should be stored under the storage temperature range. If the LCD modules will be stored for a long time, the recommend condition is:

Temperature: 0°C ~ 40°C Relatively humidity: ≤80%.

10.2.3 The LCD modules should be stored in the room without acid, alkali and harmful gas.

10.3 Transportation Precautions

10.3.1 The LCD modules should be no falling and violent shocking during transportation, and also should avoid excessive press, water, damp and sunshine.

11 LCD Introduction

11.1 Process capacity

DWIN adopts original class A glass and the entire production is in the park from cleaning, cutting, bonding, and laminating of large glass to backlight assembly, quality inspection, and aging.

There are 12,000 square meters of clean workshop, with a monthly production capacity of about 2.5 million pieces. Each piece of LCD produced in the factory is for 30 days of aging.



11.2 ODM service

Based on LCD products of 1.5~21.5 inches, DWIN provides the following customization services.

1、LCD HDMI interface customization.

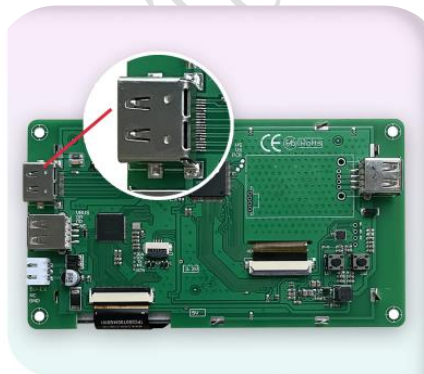

HDMI interface

2、Special screen customization such as high brightness, ultra-wide temperature and strong electromagnetic protection.

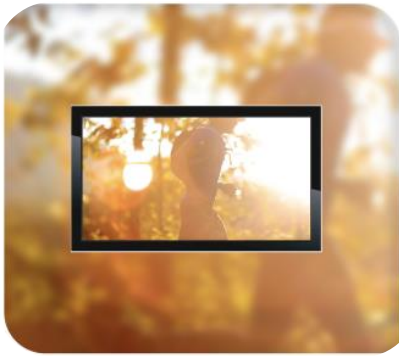

High luminance
(up to 1200nit)



Ultra-wide temperature
(-40~85℃)



Strong electromagnetic
protection

3、Lamination customization service of LCD + TP.



LCM+RTP



LCM+CTP

4、Customization service of DWIN self-developed T5L ASIC+ LCD + TP.



5、Smart screen finished product customization.

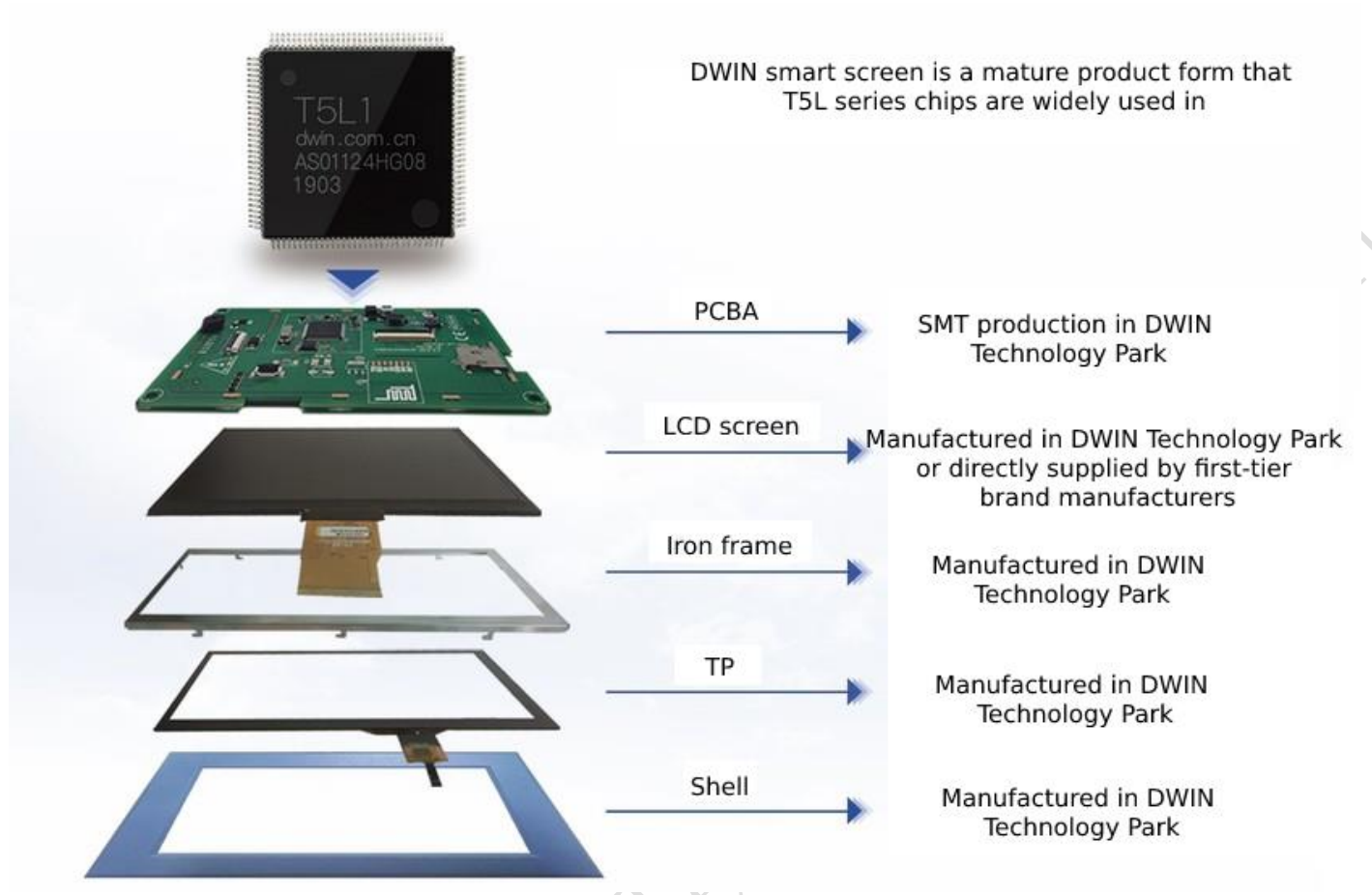

Please contact our sales staff for other customization needs.

Record of Revision

Rev	Date	Description	Editor
00	2020-11-16	First Release	Zhou Biao
01	2021-08-19	Update the PIN Terminals	Ouyang Kaixing
02	2023-01-04	Add Product Picture, Update Operating Temp and Storage Temp	Chen
03	2023-02-22	Update Packing Capacity	Chen
04	2023-05-15	Update Terminals	Chen

Please contact us if you have any questions about the use of this document or our products, or if you would like to know the latest information about our products:

Customer service tel: +86 400 018 9008

Customer service email: dwinhmi@dwin.com.cn

DWIN developer forum: <https://forums.dwin-global.com/index.php/forums/>

Thank you all for continuous support of DWIN, and your approval is the driving force of our progress!